

Kit Correderas

KIT DESL.101/102 COND.

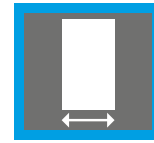

PATENTADO



Grosor 35/45 mm.



Patentado

Características técnicas

- Diseño moderno y minimalista.
- Caja extremadamente compacta para optimizar el mecanizado.
- Alta fiabilidad y accionamiento suave.
- Incluye plantilla de montaje del cerradero y cajetín.
- Productos disponible en terminación cuadrada y redonda.

Plano

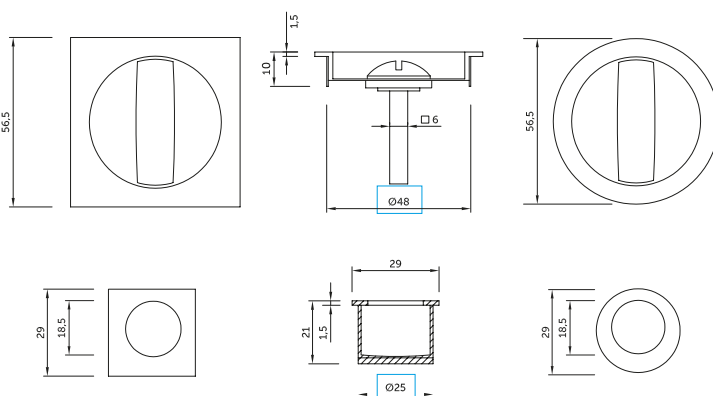
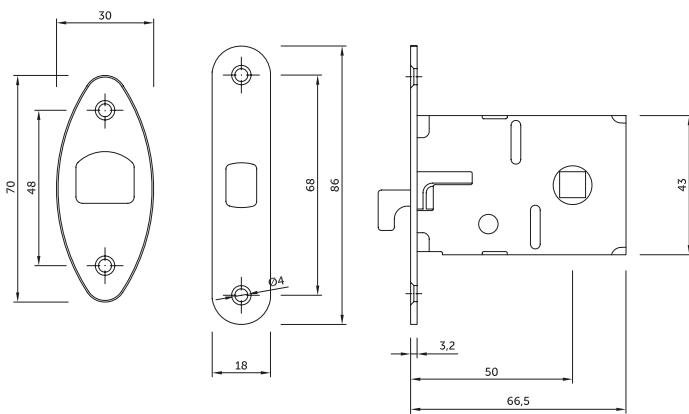
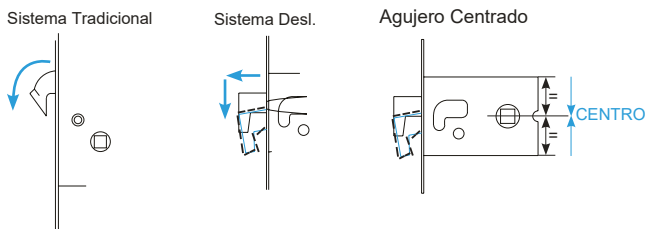

Código	Descripción	Tipo	Acabado	Set
15550	Kit Desl. 101 Cond.	C/C	NS	1/40
15552	Kit Desl. 101 Cond.	C/C	LP	1/40
15555	Kit Desl. 101 Cond.	C/C	NE	1/40
15557	Kit Desl. 101 Cond.	C/C	BL	1/40
15559	Kit Desl. 101 Cond.	C/C	LS	1/40
15561	Kit Desl. 101 Cond.	C/C	CR	1/40
15219	Kit Desl. 101 Cond.	C/C	CM	1/40
15551	Kit Desl. 102 Cond.	C/R	NS	1/40
15553	Kit Desl. 102 Cond.	C/R	LP	1/40
15554	Kit Desl. 102 Cond.	C/R	CS	1/40
15556	Kit Desl. 102 Cond.	C/R	NE	1/40
15558	Kit Desl. 102 Cond.	C/R	BL	1/40
15560	Kit Desl. 102 Cond.	C/R	LS	1/40
15562	Kit Desl. 102 Cond.	C/R	CR	1/40
15220	Kit Desl. 102 Cond.	C/R	CM	1/40

