

Cierrapuertas

CTS 300

INTHER

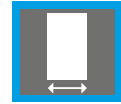

≤1000



100 kg

EN
3



Características técnicas

- Fuerza fija 3
- Ancho hoja ≤ 1000
- Regulación del golpe final 15°-0°
- Regulación Velocidad de cierre 110°-15°
- Retención 90°
- Ángulo máximo de apertura 110°
- Grosor de vidrio 8-13,5 mm.

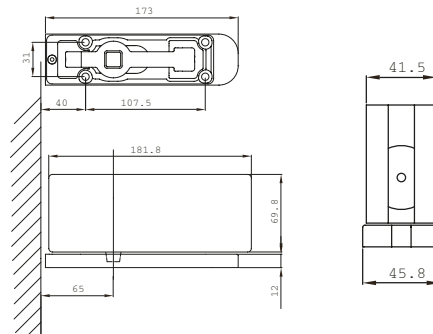

Colores disponibles



Inox

Características

Código	Descripción	Acabado	Retención	Set
13943	CIERRAPUERTAS CTS 300 EN 3	INOX	✓	1/6
13639	PERNO SUPERIOR REG. C/ROD.	-	-	1/20
14854	PINZA SUPERIOR CTS 300	INOX	-	1/6

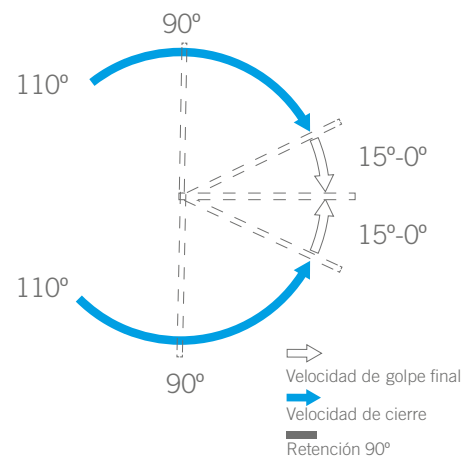

* Consulte bisagras y accesorios de cristal en el catálogo específico de herrajes de vidrio.

Descarga la declaración de prestaciones en www.inther.es

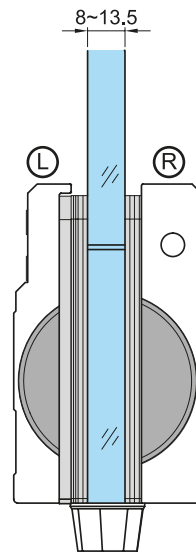
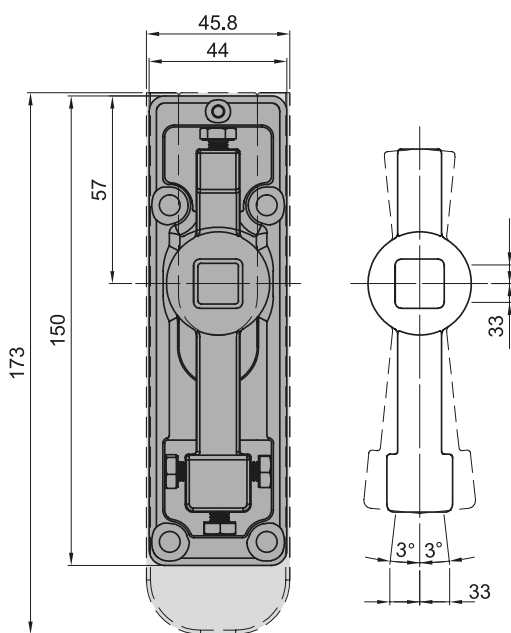
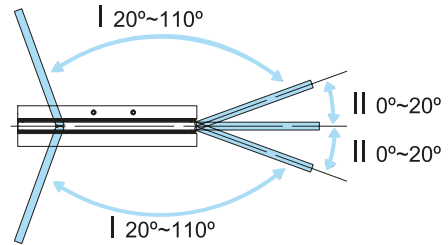
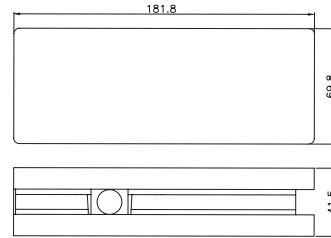
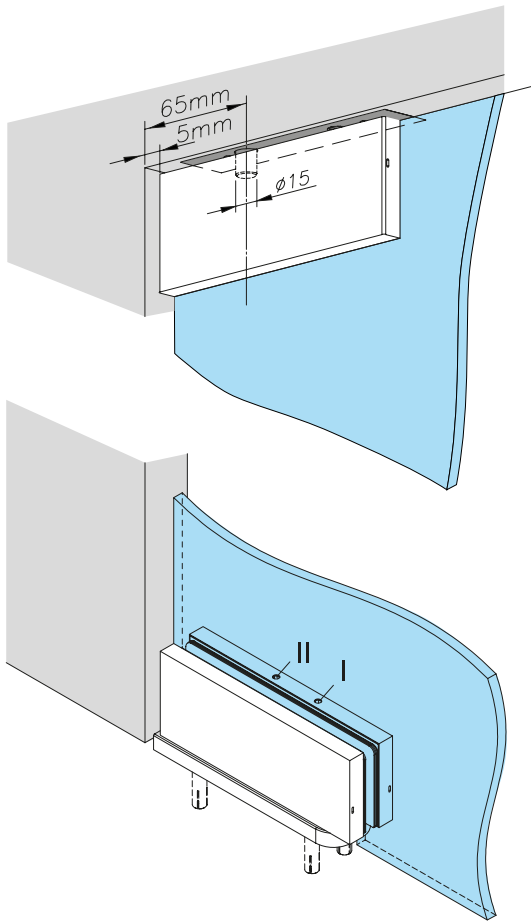

T	0.5mm		1mm		2.5t
	LR		LR		L
8	1	1	2	2	1
10	1	1	1	1	1
12	1	1	0	0	1
13.5	1	0	1	0	1

Mecanizado vidrio

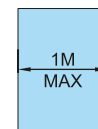
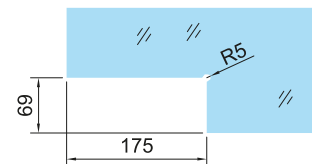

MAX
100 KG